

# Asepti-Cleanse®

Hand Sanitizer and Hands-free dispensing system

---

## Technical Data File

Hands-Free Dispensing System

For Use with DECON-AHOL® WFI Formula and DECON-HAND®

ASP-CLS-02

Revised 05 November 2013



# Asepti-Cleanse Dispensing System

## Hands-Free Dispenser

For Use with DECON-AHOL<sup>®</sup> WFI Formula, DECON-HAND<sup>®</sup>, and STERI-PEROX<sup>®</sup> 6% VAI<sup>®</sup> offers a hands-free dispensing system for DECON-AHOL WFI Formula, DECON-HAND, and STERI-PEROX 6%. The dispensing system is the most advanced infrared sensor dispensing system available in the pharmaceutical and biotechnology industries. Developed to meet the requirements of cGMP clean room operations, Asepti-Cleanse is sealed to protect the internal electronics against cleaning and disinfecting. The unit mounts directly to glass or walls, making the dispenser an excellent choice for gowning rooms or aseptic manufacturing areas.

DECON-AHOL WFI Formula and STERI-PEROX 6% are formulated for use on clean room gloves and chemical resistant gloves. (DECON-AHOL WFI Formula and STERI-PEROX 6% should not be used on bare skin.) DECON-HAND is a mild alcohol formula with emollients for use on bare hands. It may also be used on clean room gloves.

### Features:

- A sealed unit that protects the coated internal electronics; Water resistant in design.
- Photo-eye operated. Just place your hands underneath and it dispenses a pre-measured dose without contact of the person to the unit.
- Can be adjusted to dispense 1, 2, or 3mLs of DECON-AHOL WFI Formula, DECON-HAND, and STERI-PEROX 6%.
- Designed in a dual power configuration of power supply. The Asepti-Cleanse Dispensing System (DEC-301) unit can be powered by 4 D-Cell batteries (4 D-Cell batteries usually last over 1 year) or connected directly to a 110 Volt receptacle in the same unit. In the electrically mounted installations, one has the backup of the battery power if a failure in the power line occurs due to abnormal situations. Simply, it has its own backup system.
- Can mount directly on glass or walls.
- Containers are removed and replaced in seconds.
- The DECON-AHOL WFI Formula and DECON-HAND products are filtered at 0.2 microns into the Asepti-Cleanse container system. Each container is double-bag packaged and subsequently terminally sterilized via gamma irradiation. The DECON-AHOL WFI Formula and DECON-HAND products have been completely validated for assay and sterility. STERI-PEROX 6% is aseptically filtered at 0.2 microns into sterile Asepti-Cleanse containers. Each container is double-bagged packaged into gamma irradiated bags.
- Small in size – measuring 12" H x 5" W x 2" H and has a keyless opening and closing mechanism.
- Has a custom key-coded stem for product containers insuring a positive connection of the product container to the unit.

### Included in Shipment:

- (1) DEC-301 Dispenser
- (1) DEC-301 Drip-Tray
- (4) D-Cell Alkaline Batteries
- (2) Mounting Tape Strips
- (1) Attached Cover Release Button
- (1) Security Cover Release Button
- (4) Wall-Mount Screws with Anchors



## Product Numbers

DH-10	DECON-HAND instant hand sanitizer; 32oz Bottle; Sterile	12 btl/cs
DEC-301TRAY	Black Steel Drip Tray	1 ea/cs

### Asepti-Cleanse Dispensing System Instruction Manual

The Asepti-Cleanse DEC-301 Touch-Free dispenser can pump lotion, liquid soaps or sanitizers from a VAI index keyed collapsible non-refillable bottle. The clear window on the front cover allows the user to monitor the fluid level. Asepti-Cleanse is ADA (Americans with Disabilities Act) compliant and UL Medical Device listed. Battery replacement, front cover removal and actuating mechanism removal or replacement do NOT require any tools to interchange.

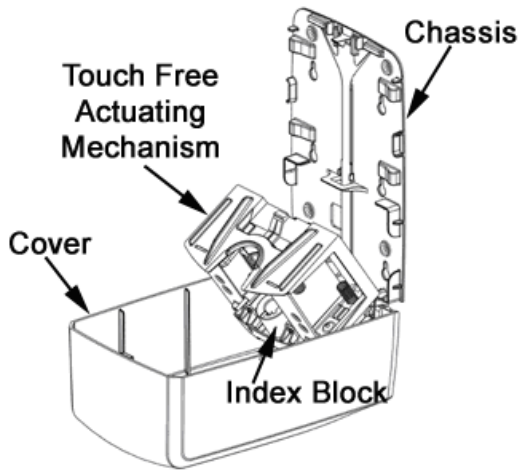

**Fig. 1**

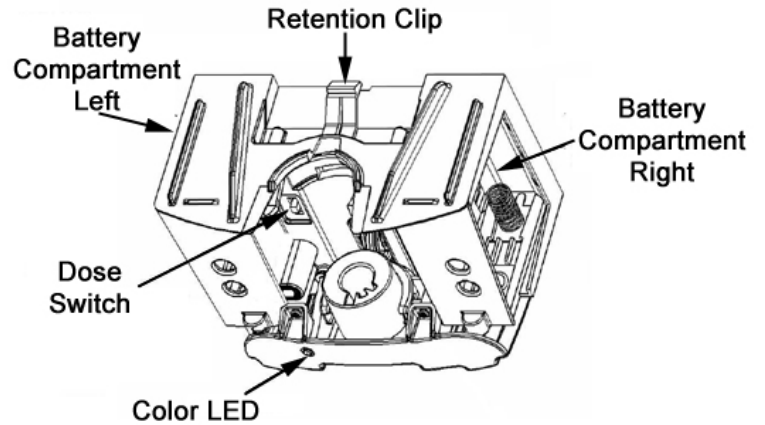

**Fig. 2**

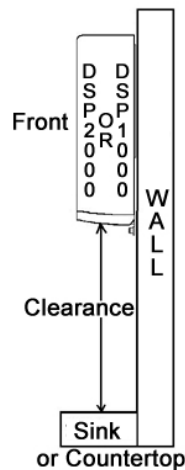

**Fig. 3**



## Mounting

The Asepti-Cleanse has a sensor selectable jumper in the back of the actuating mechanism which allows for a SHORT or LONG RANGE setting due to the unit requiring an 8 to 12 inch clearance below the sensor for proper hand detection (See Fig. 3). Please note that the Asepti-Cleanse is NOT waterproof, when selecting a mounting location. Four methods are listed below:

- Wall mount with supplied adhesive tape:**  
 First clean the mounting location with soap and water. After the area has dried, use the supplied cleaning wipe to prepare the surface for mounting. Peel off one side of the supplied mounting tape and apply one strip to the top center and the other strip to the bottom center of the Asepti-Cleanse chassis. Peel off the other side of the tape, level chassis then press firmly onto the final mounting location (See Fig. 4). Wait 24 hours before using.  
 Note: Mounting the unit with tape will cause it to be slightly over the 4" ADA depth requirement.
- Wall mount utilizing existing anchors:**  
 When replacing an existing dispenser, the base has 6 slide mount holes that match other dispensers. Make sure all the chassis screws are tight (See Fig. 5).
- New wall mount using supplied anchors and screws:** This procedure will require a small hammer, drill, drill bits, level and a screw driver. Use standard bits for dry wall and masonry bits for tile applications. Place the leveled chassis on the mounting location to transfer the drill centers. Drill 4 holes with the proper bit. Gently tap the anchors in place using a hammer. Screw the chassis tightly to the wall (See Fig. 6).
- Optional floor stand:**  
 A floor stand can accommodate the mounting of one or two Asepti-Cleanse units with drip trays for each unit. An optional 11"x17" sign holder is also available.

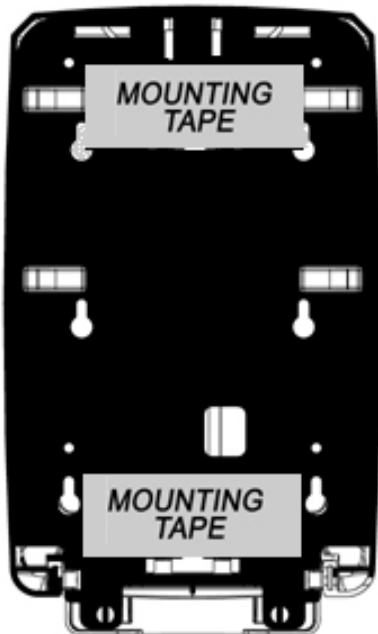

Fig. 4

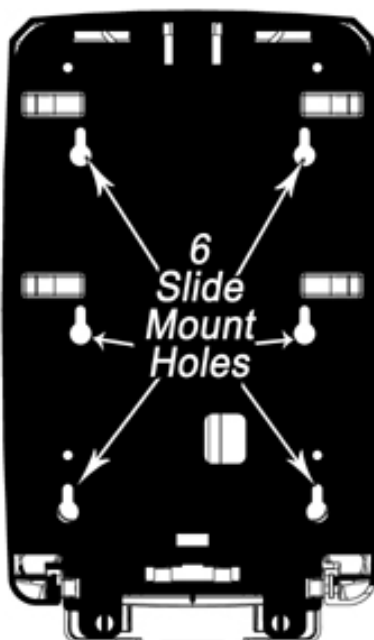

Fig. 5

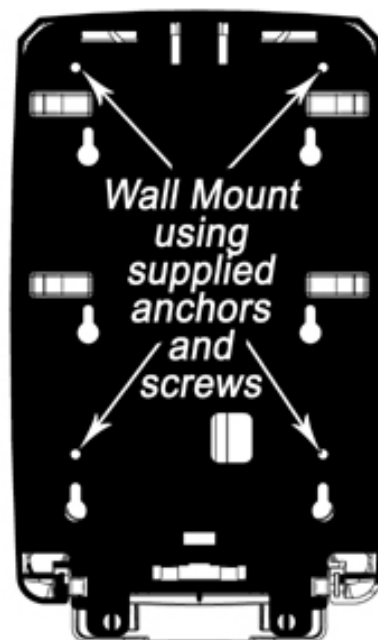

Fig. 6



**Color LED Status**

The LED is located on the front left side of the dispenser below the cover. The LED should continuously flash green when the Asepti-Cleanse cover is closed and the batteries are good. If the LED is not flashing, then either the batteries are dead or not installed properly (See Fig. 7).

1. Green flash once a second – Batteries are good and the cover is closed
2. Green flash twice a second – Front cover open (the unit will not dispense)
3. Red flash once a second – Low battery power (change batteries soon)
4. Red flash twice a second – Change the batteries (the unit will not dispense)
5. Alternating Red / Green flash – Sensor obstruction (maintain a 8-12" clearance below sensor)

**Cover Release Options**

The user can select a Security (See Fig. 8) or an Attached cover release (See Fig. 9). Depressing the cover release will unlatch and allow the cover to open.

*Security:* The Security cover release must be put in place each time a user needs to open the front cover. The Security cover release option prevents unauthorized opening of the dispenser. Place your thumb on the security cover release and insert the top two tips into the case location (See Fig. 8 and Fig. 10).

*Attached:* The Attached cover release is used for easy access to open the front cover. Once the Attached cover release is inserted it will lock into place. To install the Attached cover release, correctly orientate the teeth facing up, then insert into the case location. To uninstall, remove the actuating mechanism (See Fig.11), then insert a small blade flat tip screwdriver between the two teeth and pry up gently until you can pull out the Attached cover release (See Fig. 9 and Fig. 10).



**Fig. 7**



**Fig. 8**



**Fig. 9**

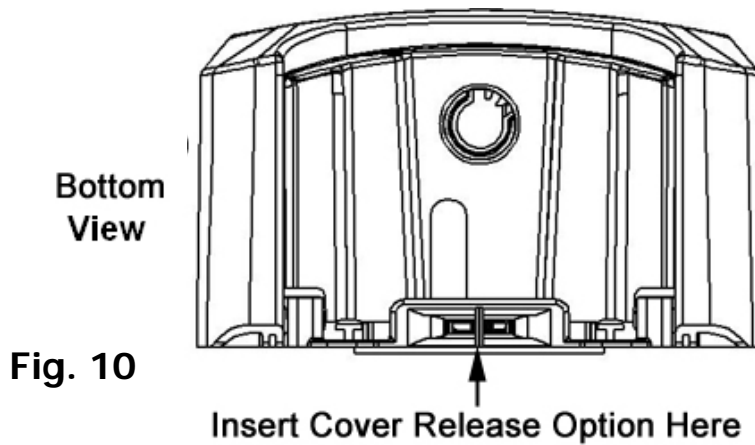



### Removing the Actuating Mechanism

To remove the actuating mechanism, depress the Retention Clip located at the top of the actuating mechanism to unlatch and pivot forward to remove. To reinstall, place the bottom 2 pivot points into the chassis base and pivot the top towards the chassis until the actuating mechanism latches and clicks into place (See Fig. 11).

### Option Settings

- Dose Switch 1-2-3  
 The switch is located in the middle of the touch free actuating mechanism, (See Fig. 11) behind the front cover. Each cycle will dispense approximately 1ml of liquid or .75 ml of foam solution. Example, setting the switch on setting 3 will activate the dispenser 3 times (cycles) for approximately a 3ml dosage
- SPEED and RANGE Jumpers  
 Remove the touch free actuating mechanism to access the jumpers located on the back side of the casing.

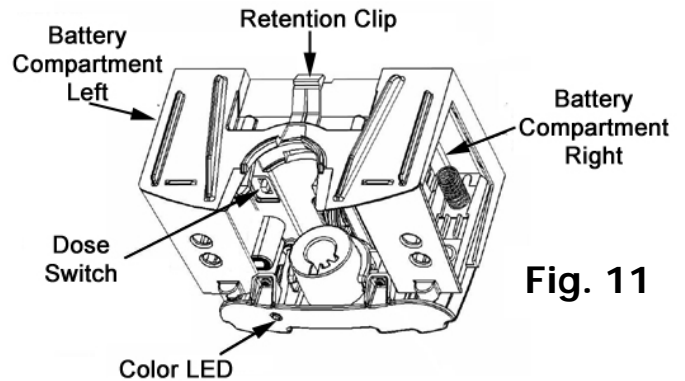

**Fig. 11**

**SPEED:** Some Lotion solutions are more viscous than others; this may create a splashing problem when solution is dispensed. To eliminate this problem, change the dispense speed setting from FAST (default) to SLOW by pulling the jumper and setting it on the correct pins. For foam always use the FAST setting.

**RANGE:** Hand sensor range. LONG RANGE (default) is approximately 3 to 6 inches from unit base; SHORT RANGE is approximately 2 to 4 inches. Remove the jumper and set it on the correct pin for the desired range. The dispenser will NOT work without a jumper in place. Only adjust the RANGE setting when needed during installation.

### Bottle Information

Each sanitary non-refillable 1.25 liter bottle is factory sealed. The bottles are disposable and are NOT made to be refilled. Each bottle comes with a keyed nozzle which fits into the corresponding keyed actuating mechanism (See Fig. 12).



**Fig. 12**

## **Bottle Installation**

Depress the cover release to drop down the front cover (See Fig. 10). Remove the bottle nozzle protective cap. Invert the bottle and remove the vent plug if one is provided. Insert the nozzle tip into the proprietary bottle index block located in the middle of the actuating mechanism. Pivot the bottle top until it clips into the actuating mechanism clamp. Do NOT depress the pump nozzle in the inverted position because this will cause fluid to dispense. Close the cover and activate the dispenser a few times until the pump is primed (See Fig. 13).



**Fig. 13**

## **Bottle Removal**

Approach the cover release from the side while keeping hand away from the centrally located hand-sensing elements. Releasing the latch in this manner will avoid needless discharge of soap. Grasp the top of the bottle and pivot forward to unclip and remove the bottle (See Fig. 14). While the covers open the unit will not dispense.



**Fig. 14**

## **Dispensing**

Place your cupped hand approximately 2 to 6 inches below the dispenser's bottom. The Asepti-Cleanse sensor will detect your hand and then dispense a calibrated amount of either foam or liquid chemical onto your hand (See Fig. 15).

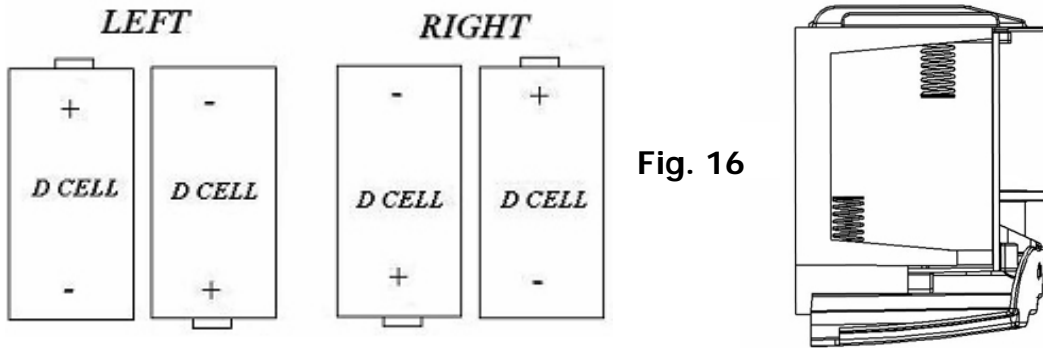

**Fig. 15**



**Battery Compartment**

Four D size professional alkaline batteries are required to power the unit. The unit contains two battery compartments, one on each side of the dispenser. Install two batteries in each compartment. Load the space toward the back of the compartment first. Place the flat (negative) end of the battery against the spring and depress the spring until the positive end can be moved in the place. Each battery must have the negative end in contact with the spring. Load the remaining batteries in a similar fashion (See Fig. 16).



**Replacing the Front Cover**

Depress cover release to open (See Fig. 10). Pull the covers lower pivot points outwards until the cover detaches from the chassis base (See Fig. 17). Reverse the process to reinstall.

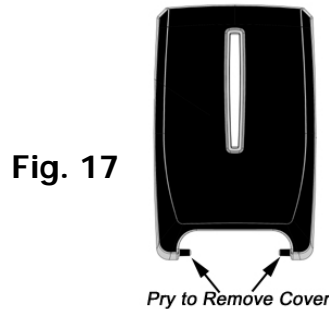

**Cleaning**

The exterior can be cleaned with a NON abrasive detergent and a NON abrasive sponge or cloth. Make sure to clean the window on the lower portion of the Asepti-Cleanse actuating mechanism as this window allows the dispenser to recognize that a hand is below it (See Fig. 18).

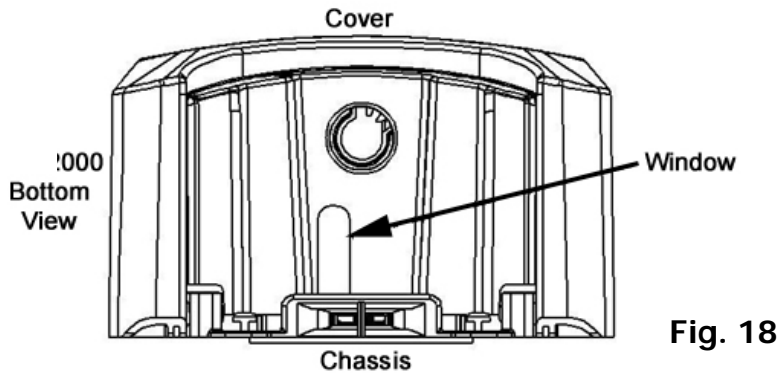



## **Troubleshooting**

No Dispense No LED	<ol style="list-style-type: none"> <li>1. The batteries require changing.</li> <li>2. The batteries are not installed properly.</li> <li>3. Check battery polarity</li> </ol>
The dispenser works fine but NO LED	The unit is defective
No dispense. The LED flashes Green twice a second	<ol style="list-style-type: none"> <li>1. Close the cover</li> <li>2. The Chassis is not attached to wall securely.</li> <li>3. The Chassis is not attached with 4 wall anchors.</li> </ol>
No dispense. The LED flashes Red twice a second	The batteries require changing.
No dispense. The LED flashes Green once a second	<ol style="list-style-type: none"> <li>1. The RANGE jumper is missing or not properly installed</li> <li>2. Perform dispense cycle a few times to Prime pump.</li> <li>3. The bottle is empty.</li> </ol>
No dispense. The LED flashes alternating Red / Green	<ol style="list-style-type: none"> <li>1. There is an obstruction below the IR sensor.</li> <li>2. Check for soap on the IR cover window (See Fig.15)</li> <li>3. Change the RANGE jumper from LONG to SHORT</li> </ol>
The unit dispenses too much fluid.	Check the Dose Switch setting. Set to a lower dosage.
Poor foam quality	Change the Speed jumper.
The unit dispenses without activating the sensor	Maintain a 8-12" clearance below the sensor Change the RANGE jumper from LONG to SHORT.

**Patent Pending**

